

---

## Design of Portable Parking System Using Android-Based QR Code

Muhammad Benny Chaniago<sup>1)</sup>, Rizky Hardiana<sup>2)</sup>, Hadi Pratama Wijaya<sup>3)</sup>, Fazri Ramadhan<sup>4)</sup>, Rizki Hamzah Abdul Gani<sup>5)</sup>, Nando Agung Dwi Saksono<sup>6)</sup>

<sup>1,2,3,4,5,6)</sup> Affiliation (Information Systems Department, Widyatama University, Bandung, Indonesia

Corresponding author: [benny.chaniago@widyatama.ac.id](mailto:benny.chaniago@widyatama.ac.id)

### Abstract

*The rise of parking in the highway area (on-street parking) often causes problems in several places where vehicle users who will pick up each other wait at the entrance gate to the business center. In overcoming these problems, parking managers usually help vehicle users who will park by placing a parking information board in the parking lot's entrance area, which is generally about parking space availability in the parking lot. Although it helps, the vehicle that will park often does not see the parking information board, thus causing congestion. Along with the development of technology, the parking system is experiencing very rapid growth from year to year. The automatic parking system integrated with the database system has replaced the manual parking system. In addition, a Quick Response Code, better known as QR Code, is often used for commercial purposes. In this study, parking customers use a QR Code as an ID instead of a paper parking card. Parking data collection begins with parking users scanning the QR Code in the parking machine through the parking application installed on an android smartphone. In the parking application installed on the mobile phone, parking customers can find out the parking hours in, the parking hours out, and the duration of parking. After the QR Code scan process is successful, the Arduino microcontroller and the HC-SR04 sensor as the doorstop controller will open and close the doorstop automatically. This parking system integrates a database system with a smartphone so that parking users will feel more secure and comfortable.*

*Keywords: Parking System, QR Code, Arduino, Android*

### INTRODUCTION

In today's modern era, information about parking availability becomes an essential thing to note. The increasing number of people in Indonesia, especially those who have motor vehicles from year to year, make the streets in Indonesia more crowded and crowded. In 2019, the number of cars increased by 7,108,236 units or increased 5.3 percent to 133,617,012 units from the previous year to 126,508,776 units. The number of vehicles in 2018 rose 5.9 percent from 2017 to 118,922,708 units [1]. In Java alone in 2020, it ranks first in cars, reaching 83 million units. The number of vehicles consists of 11 million units of private vehicles, 64 million units of motorcycles [2]. Undoubtedly, big cities such as Bandung and Jakarta have parking problems where vehicle users who park in the road area (on-street parking) become very much. The Government already has the policy to reduce parking in the street area by requiring centers of business activities such as malls, restaurants, hospitals, and offices to provide a parking space that meets the standards. The problem that arises is the length of time waiting for vehicles in the parking lot due to the long inspection of parking fees, making car drivers have to wait to cause a buildup of vehicles in the parking lot.

To overcome the above problems, it is necessary to do away so that vehicle users can quickly park in the parking lot. The use of *QR codes* today is used for commercial aspects. However, it has been widely used in various elements, and related to this research is how to create a concept of parking system design that will make vehicle users become time-saving and reduce waiting time, of course. This application is based on Android so that vehicle users will install it on their smartphones in practice. Vehicle users only have to *scan* the *QR Code* on the parking machine through this parking system application, the input when the rider parks.

### **QR Code**

QR Code stands for Quick Response Code. QR Code was developed by Denso Corporation, a Japanese automotive company [3]. In 1994 a QR Code was issued to track vehicles in manufactures quickly and get a fast response.



**Image 1. QR Code**

(Source: [en.wikipedia.org/wiki/QR\\_code](https://en.wikipedia.org/wiki/QR_code))

As the QR Code developed, more and more researchers researched this symbol code. Various stuAs a result, different tinges to create to increase the amount of data stored in QR Codes, increase resistance to damage, and others. Some of the studies that have been carried out include: [4]:

1. Creation of *QR Code* reading application
2. *QR Code* for digital signatures
3. *QR Code* for novel user authentication
4. *QR Code* for Education

According to [5], examples of *QR Code* implementation in the business and industry world can be found in Australia, China, Hong Kong, Japan, Korea, Singapore, and Taiwan, among others:

1. Blood test process management in Australia
2. LPG cylinder bottle management in Australia
3. Jewelry certification in China
4. Bus commuters pass issuing system in Japan
5. Control the level of freshness of sushi in Japan

### **Arduino Microcontroller**

Arduino microcontroller device is a *board* of microcontrollers based on IC ATmega328P. It has 14 digital input/output pins (which can be used as PWM output), six analog inputs, 16 MHz quartz crystals, USB connections, power plugs, ICSP headers, and reset buttons. Thus, the device contains everything needed to support a microcontroller. We connect to the computer with a USB cable or run it with an AC adapter to DC or use the battery to start running it. In addition, we can tamper with your UNO without worrying too much about making mistakes [6].

### **Mobile Apps**

Mobile applications are developing applications made for handheld devices, mobile phones, PDAs, or better known as smartphones. The app is already on the phone when the manufacturing process, referred to as the built-in application. Users can also download applications from the app store and other platform car software distribution [7].

### **Android**

The mobile app used is Android-based. Android is a Linux-based operating system designed for touchscreen mobile devices such as smartphones and tablet computers [8]. Android's user interface is based on direct manipulation, using touch input similar to real-world actions, such as swiping, tapping, pinching, and flipping pinches. Android is an open-source operating system, and Google released its code under the Apache license [9].

### **Motor Servo DC**

"DC Servo Motor become an important device in a wide range of industrial applications that require high dynamics on position control such as numerically controlled machinery, robotics, automation and other mechanisms where the starting and stopping functions are quickly and accurately" [10].

The quote above shows that many applications use servo motors, especially in industrial applications requiring dynamic position control accuracies, such as numerical, robotics, automation, and other devices.

A servo motor is a motor that is regulated and controlled using pulses. This motor consists of 2 types, namely standard servo motor and continuous-servo motor. The stock servo motor can only move in two

directions (CW and CCW) with a deflection of 90o at each angle so that the total angular deflection from the right-center-left is 180o. While the continuous servo motor is a servo motor whose feedback part is removed so that this type of servo motor can move both ways (CW and CCW) without the limitation of turning angle deflection until it reaches an angle of 360o (can rotate continuously) [11].

#### Sensor HC-SR04

The HC-SR04 is an ultrasonic sensor module designed to be planted in a project. Range of ultrasonic sensors between 2 cm – 400 cm [12]. According to HC-SR04 has the following pin criteria [13]:

**Table 1. HC-SR04 Sensor Pin Clears**

No	Pin Name	Explanation
1	VCC	Pin the source of a positive voltage of 5V.
2	Trig	Trigger. Used to generate a signal ultrasonic.
3	Echo	<i>Receiver</i> / Indicator. Used to detect the signal ultrasonic reflection.
4	GND	Ground / 0V.

#### Parking Next to The Street (*On-Street*)

*On-street* parking is a parking lot or street space (usually taking up an area designated for pedestrians, causing congestion on the road).



**Image 2. On-Street Parking is Legal**  
(Source: flickr.com/photos/jennofarc)



**Image 3. Illegal On-Street Parking**  
(Source: [www.motorplus-online.com](http://www.motorplus-online.com))

**RESULTS AND DISCUSSIONS**

**Software and Hardware Needs**

In the design of this parking system, the author uses several applications in its development, among others:

1. IDE Arduino
2. Android Studio
3. Android Emulator
4. Dreamweaver
5. 3T Studies
6. Visual Studio Code pe

The microcontroller hardware used is:

1. Arduino Uno R3
2. Sensor HC-SR04
3. Motor Servo

The planned system will have the following workflow series. User starts from the user registering in the application using an ID Card. After that, the user tops up the balance in the application. When finished, the user can select the parking space to be addressed by choosing the menu to find a parking space. The system will display the location and the available parking capacity. Then the user comes to the intended parking lot and then checks in in the application by scanning the barcode at the portable parking entrance. After that, the gate will send barcode ID data into the parking database then the gate will send a signal to the doorstop to open. Furthermore, the system will update the parking status to in, and payroll will run according to parking time. The image below shows the workflow of a portable parking system.

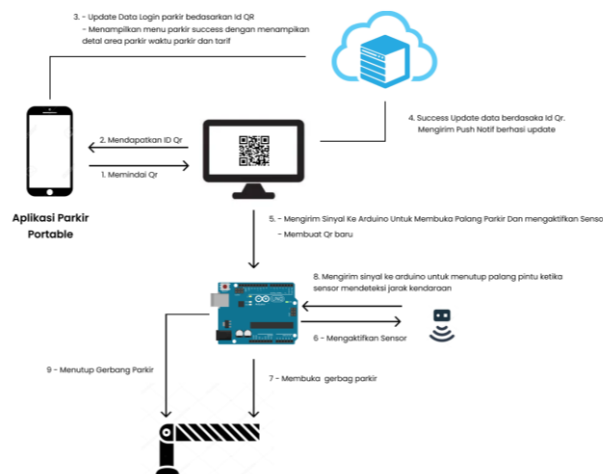

**Image 4. Portable Parking System Workflow**

The Use Case diagram in the design of this portable parking system has two entities, namely *User / Rider* and *Admin*

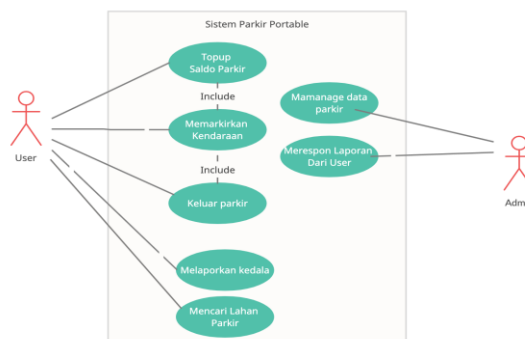

**Image 5. Portable Parking System Use Case Diagram**

The design of the table in this study is as follows:

**Table 2. Parking Data Table**

No	Field Name	Data Type	Length
1	Parking ID*	Varchar	6
2	ID_Card**	Varchar	16
3	Time_In	Date/Time	
4	Time_Out	Date/Time	
5	Time	Date/Time	
6	Parking_Duration	Date/Time	

**Table 3. Vehicle Driver Table**

No	Field Name	Data Type	Length
1	ID_Card*	Varchar	16
2	Driver_Name	Varchar	25
3	Status	Varchar	10
4	Address	Varchar	40
5	Phone_Number	Varchar	13
6	QR_Code	Blob	

**Table 4. Admin Login Table**

No	Field Name	Data Type	Length
1	Username	Varchar	10
2	Password	Varchar	12
3	Name_Admin	Varchar	25
4	Phone_Number	Varchar	13

Table 5. User Login Table

No	Field Name	Data Type	Length
1	Username	Varchar	10
2	Password	Varchar	12

Arduino microcontroller circuit, when the QR Code can be scanned, according to the data contained in the database, the computer gives a command signal received by Arduino and moves the servo motor. The doorstop will open or lift upwards. The HC-SR04 sensor accepts objects, namely vehicles. If the car passes through the sensor, the sensor will provide input to the Arduino microcontroller to close the doorstop again. Here's the Arduino series:

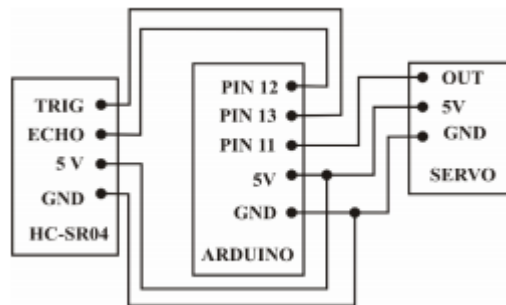

Image 6. Arduino Circuit

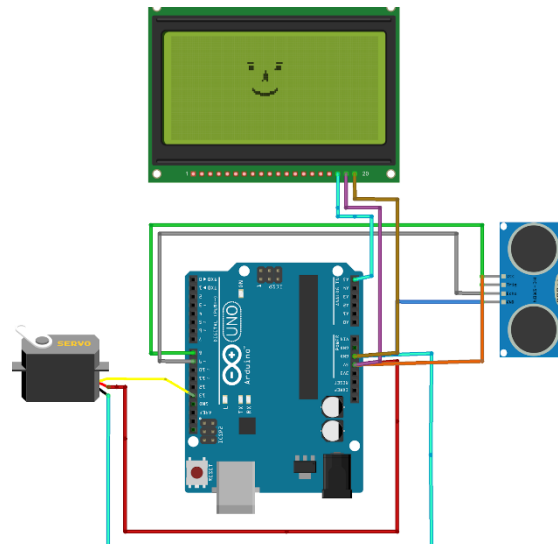

Image 7. Arduino IoT Schematic Circuit

Testing is done by way of vehicles passing through and entering the parking lot. The doorstop receives the appropriate signal and QR. The entrance and exit bars work well according to the instructions.

The design of this user interface is shown in Figure 8, which is a display for the Splash Screen menu and Figure 9 for the main user menu. Again, several fields appear, namely a location search box, a map display of the location of the parking lot, the number of parking locations, and parking rates:



**Image 8. App Splash Screen View**

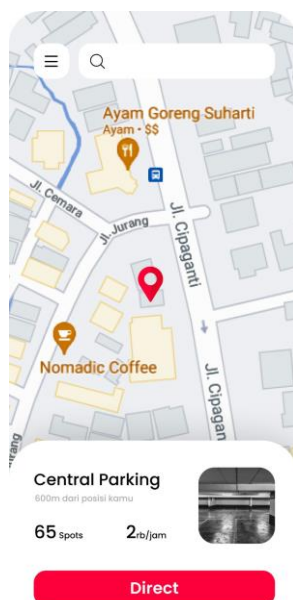
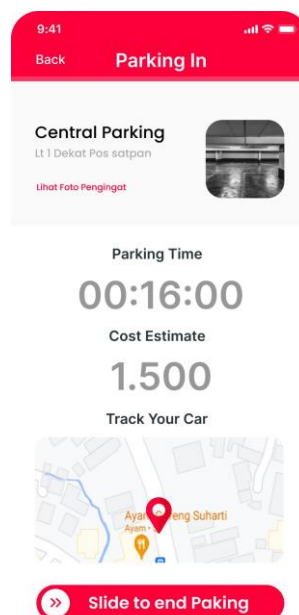

**Image 9. User Main Menu View**

Next is the interface display design for the administrator, Image 10 is the application display menu when trying to scan the pad of a parking machine, and Image 11 is the design of the user's main menu interface display after checking in the parking lot. There is the name of the parking lot, a picture of the parking location, the duration of parking, parking rates, the display of the parking location map, and button-to-end parking.



**Image 10. App QR Scan Feature View**



**Image 11. User Menu View After Parking Check-in**

## CONCLUSION

From the results of the discussion of the Design of Portable Parking System Using Android-Based QR Code, it can be concluded:

1. The use of QR Code can be used for buying and selling transactions in trade only, but QR Codes can help the parking system for vehicles. With the QR Code, the vehicle can be seconded to enter the parking area and facilitate payment transactions in the park.

2. This portable parking system can be an alternative park around us coupled with using QR Code as an entrance code and supporting transaction tools for vehicles entering the parking area. So that the riders efficiently do parking activities independently both in transactions and in-park activities.
3. This portable parking system can reduce traffic congestion around the location of the business activity center caused by the length of the vehicle entry process into the parking lot.

## Reference

- [1] Gakindo. "Hasil Sensus BPS: Jumlah Kendaraan Bermotor di Indonesia Tembus 133 Juta Unit – GAIKINDO." 2021. <https://www.gaikindo.or.id/data-bps-jumlah-kendaraan-bermotor-di-indonesia-tembus-133-juta-unit> (accessed Jun. 29, 2021)
- [2] Ahdira, A., "Pulau Jawa Jadi Daerah Termacet di Indonesia, Populasi Kendaraan Capai 85 Juta Unit - Pikiran-Rakyat.com," 2021. <https://www.pikiran-rakyat.com/otomotif/pr-011219471/pulau-jawa-jadi-daerah-termacet-di-indonesia-populasi-kendaraan-capai-85-juta-unit> (accessed Jun. 29, 2021).
- [3] M. Swapnil dan N. Wankhade, "Image Embedding in QR Code," 2021.
- [4] Pasca Nugraha, M., & Rinaldi Munir, I. M, "Pengembangan Aplikasi QR Code Generator dan QR Code Reader dari Data Berbentuk Image," *informatika.stei.itb.ac.id*," 2011. [https://informatika.stei.itb.ac.id/~rinaldi.munir/TA/Makalah\\_TA\\_Pasca\\_Nugraha.pdf](https://informatika.stei.itb.ac.id/~rinaldi.munir/TA/Makalah_TA_Pasca_Nugraha.pdf) (accessed Jul. 05, 2021).
- [5] Rahmayani, A., ITS, M. I.-J. S. dan S., & 2016, undefined, "Perancangan dan Implementasi Perangkat Lunak Sistem Pendukung Keputusan Multi Kriteria Menggunakan Metode TOPSIS", *Ejurnal.Its.Ac.Id*," 2016. [http://ejurnal.its.ac.id/index.php/sains\\_seni/article/view/17163](http://ejurnal.its.ac.id/index.php/sains_seni/article/view/17163) (accessed Jul. 05, 2021).
- [6] Aris Prastyo, E, "Arduino Uno R3 - Arduino Indonesia | Tutorial Lengkap Arduino Bahasa Indonesia."2021. <https://www.arduinoindonesia.id/2018/08/arduino-uno-r3> (accessed Jul. 05, 2021).
- [7] IDprogrammer, "Pengertian Keunggulan Serta Manfaat Aplikasi Mobile," *Idprogrammer.Com*, 2019. <https://idprogrammer.com/pengertian-aplikasi-mobile> (accessed Jul. 05, 2021).
- [8] Nazruddin Safaat H, *Aplikasi Berbasis Android*. 2013.
- [9] Setiawan, I., LastName, T. G.-P. S., & LastName2016, undefined,"APLIKASI DAYA DUKUNG DANAU DALAM BUDIDAYA IKAN AIR TAWAR BERBASIS ANDROID", *Research-Report.Umm.Ac.Id*, 2016. <http://research-report.umm.ac.id/index.php/sentra/article/view/1882> (accessed Jul. 05, 2021).
- [10] Haidar, A. M., Benachaiba, C., Zahir, M., Haidar, A. M., Benachaiba, C., Zahir, M., & Haidar, A. M. A," Software interfacing of servo motor with microcontroller," In *Journal of Electrical Systems* (Vol. 9, Issue 1), 2013. <https://ro.uow.edu.au/eispapers/468>:<https://ro.uow.edu.au/eispapers/468> (accessed Jul. 05, 2021).
- [11] Setiawan, D., Syahputra, T., 1, M. I.-J. R. V. 3 N., & 2014, undefined, "Rancang Bangun Alat Pembuka dan Penutup Tong Sampah Otomatis berbasis Mikrokontroler," 2014. *Is.Its.Ac.Id*. <http://is.its.ac.id/pubs/oajis/index.php/home/detail/1289/RANCANG-BANGUNALAT-PEMBUKA-DAN-PENUTUP-TONG-SAMPAH-OTOMATIS-BERBASIS-MIKROKONTROLER> (accessed Jul. 05, 2021).
- [12] M Kaur, J. P, *Distance measurement of object by ultrasonic sensor HC-SR04*. 2021.
- [13] X Chen, C. W, *Ultrasonic Measurement System with Infrared Communication Technology*. 2011