

# Entrepreneurs in Tourism Areas: Motivations, Problems, and Success Factors (A Case Study of Entrepreneurs in Pangandaran Tourism Area)

Iin Mu'minah<sup>1</sup>, S. B. Hari Lubis<sup>2</sup>

<sup>1</sup>Department of Industrial Engineering, Widyatama University (Utama), Indonesia

<sup>2</sup>Department of Industrial Engineering, Institute of Technology Bandung (ITB), Indonesia

## Abstract

The purpose of this research is to profile or identify characteristics of SMEs (Small Medium Enterprises) entrepreneurs in a tourism area. This is because a tourism area has many unique phenomenas. The phenomenas could be identified by smart people (entrepreneurs) who could realize opportunities or potentials into their own business. However, not all of the entrepreneurs could survive for a long time. Only limited SMEs entrepreneurs had been successfully running their business.

This research was a case study of Pangandaran tourism area. Pangandaran is a sub-district located in the south of West Java Province. Pangandaran has two beaches where people can satisfy themselves by watching the sunrise and the sun set while swimming.

By this research, data collected by interviewing SMEs entrepreneurs used questionnaire as a guideline. These questionnaires are about motivations, problems, and success factors of the entrepreneurs. Eight entrepreneurs were interviewed. Each represented one product/ commodity or one service available in the tourism area. They were selected because they have been success running their business more than ten years continually.

Techniques of analysis used were by creating matrix tabulation of entrepreneur's development. Outcomes or findings of this research hope fully could stimulate growths of emerging entrepreneurs more rapidly and could also as a consideration for government in developing appropriate policies or regulations of a tourism area.

*Keywords: entrepreneurs, small business enterprises, Pangandaran, tourism area, regulation*

## 1. Introductions

Topics on small medium business enterprises (SMEs) and entrepreneurship are getting more attentions nowadays in Indonesia. These are because SMEs have many unique characteristics in which differ it with large business. Indonesian Government are seemed to be likely gives more stress to the growths of SMEs, especially since Indonesia had been crises of monetary in year 1997. SMEs had proven to survive and could effectively create broadly new work opportunities formally or informally.

This research focused on describing profiles of entrepreneurs in a tourism area. They are about motivations, problems and success factors of entrepreneurs in running their business. This study is an exploratory case study of entrepreneurship in Pangandaran tourism area.

### 1.2 Background: A Brief of Pangandaran

Pangandaran tourism area is a sub-district of Ciamis and located at the most south of West Java Province. Its geographically is surrounded directly by Samudera Indonesia (Indonesian Ocean).

Pangandaran, based on its geographical shape is a peninsula, and has 2 beaches (bays). Each beach is named as Pantai Timur (east beach) and Pantai Barat (west beach). The most unique phenomena is that people can watch easily the sun rises at Pantai Timur early in the morning, and can watch the sun sets at Pantai Barat at the latest afternoon. These two kinds of activities are possible to do while swimming freely. The distant between Pantai Timur and Pantai Barat is only about 200 meters. At those beaches all people will get the same treat without discrimination of racism, beliefs, gender, tribes, etc.

On every weekend or holiday, especially long holiday, enourmous tourists like to come to visit this tourism area for a short holiday or just for one day break. The tourists comes from many other cities in Indonesia such as: Tasikmalaya, Bandung, Yogyakarta, Jakarta, etc. They visited Pangandaran to have many interesting pleasures, because Pangandaran tourism area has many advantages:

a). Has a well-kown natural preservation and also a wild-life preservation. In this preservation, there are many endangered species and many rarely plants or protected

crops. In this natural preservation, *Rafflesia arnoldi*, the most biggest flower in Indonesia (and could be the biggest flower in the world) grows naturally. The diameter of the flower could be 3 - 4 meters. *Rafflesia arnoldi* can attract many kinds of insects to digest by the flower. This *Rafflesia arnoldi*, becomes important object of visit for many societies: academist, researcher, lecturer, and also common foreign and domestic tourists.

- b). There are many historical things, since colonisation period of Dutch and Japan. As for examples: there are many big caves in front of Pantai Timur and Pantai Barat which were used in the past for war defense.
- c). Has interesting undersea lives of biotas. Many types of colourful fish, shrimps, lobsters, and other small botani life, which is very interesting location to people to watch underseas-life.

As described previous, these kinds of routines on every weekend or every holiday, are captured by some intelligent people to create some business in order to serve tourists to get their needs during their vacations. As a result, many kinds of business were emerged and are steal emerging in the tourism area. Usually the such business are of these types: primary meal and drinks (including fruits and vegetables), clothes, seafood, sea-craft souvenir, derivatif sea-product, motels and so on.

However, almost all of tourist visits most likely happened on such vacation or holiday. Rarely tourists would like to visit the area on weekdays. This is because of many reasons, but in general, the access to Pangandaran tourism area is barely hard to achieve from another city. The tourism area is only can reach by land transportation, but there are no appropriate public transportations available especially in the night.

As seen on Figure 1, Pangandaran tourism area (cited on red bullet highlight) is directly surrounded by Indonesian Ocean at the south-side. It needs about 6-7 hours car/ bus driving from Bandung as capital of West Java Province, or about 300s kilometers in distant. This such condition, of course affects to the number of tourist visit. They would only like to come to Pangandaran tourism area in a quite long weekend or holidays.



Figure 1. Pangandaran on West Java Map

The condition is getting worse because physically, Pangandaran is also isolated by teak forrest land-hill without appropriate light supply, especially in the night, in both sides (left and right) of the roads. The route is also very lane so many people in common, usually do not like to have this type of travelling because this situation can make people get into 'travelling-sickness'.

In addition, there is no sufficient public facility such as banking access, (limited bank and its automatic teller machines), limited gas-station, and there is no appropriate hospital. This condition would be getting worse if suddenly any accidents happened. This could be the worst if tourist was sunk in the sea or was crashed by motorboat.

In the past, about 1970s – 1990s era, there was a mass public transportation i.e short train which generated by coal machines, but present this kind of transportation is unavailable because district government had stopped the operations.

In early of year 2000s, state government of West Java Province, made a joint cooperation with PT. Merpati Nusantara, an airplanes corporations in Indonesia, prepare direct flight to Pangandaran from the capital of Indonesia through Bandung. The two flight routes are: Jakarta-Bandung-Pangandaran. The flight were third times per week. The reason of this cooperation is to broaden access to Pangandaran tourism area. Hopefully not only domestic tourists would like to visit, but also foreign tourists outside Indonesia

However, the cooperation was not running for a long time. Such collaboration existed only

for about one year. At the end, the flight from Jakarta – Bandung – Pangandaran had been stopped because the flight was only full-occupied at long weekend and holidays, not on weekdays.

As previously described, it can be concluded that tourist visits is only in a limited time (temporary) with a huge number of tourists. This condition causes an enormous needs or potential market demand to supply in a tourism area. These routines phenomenas were figured out by many smart people (entrepreneurs). They made their own business by preparing goods and services for tourists in tourism areas. However, not all of the entrepreneurs could survive in running their business for a long time, because there were many problems or barriers arised during running their busines.

### 1.3 Aims of Study

This research focused on study of entrepreneurs' profiles in a tourism area who exist for more than ten year running their business. They are about motivations in creating the business, problems faced during operating of their business and success factors of managing the business. This research hopefully could stimulate growths of SMEs entrepreneurs in Indonesia by generating new entrepreneurs, and could be a consideration for district (and state) government in making appropriate policies or regulations in such tourism areas.



Figures 2. Pantai Timur and Pantai Barat of Pangandaran Tourism Areas

## 2. Literature Review

Bamford & Bruton (2010) wrote that small business enterprise has always been a critical part of the country's success. The development of small business is an important driver of the

economic success of a community, a region, and a state or a nations.

Small business and medium enterprises (SMEs) in Indonesia are defined in many ways by many different institutions/ organizations. These organisationa are: The Indonesian Bank, BPS (Center of Statistic Burreau), Department of Trade and Industry, Department of Small Business and Cooperation, etc.

However, this research uses termonology of SMEs referring to UU No.9/1995, pasal 5. SMEs were indicated by many of following factors:

- Having nett asset not more than Rp. 200.000.000 (two hundreds millions rupiahs), excluded its land and its building.
- Annually omzet less than Rp. 1.000.000.000. (one billion rupiahs)
- Independent, not affiliated with large firms.
- Private status: private owned business or in a cooperation firm.

Further, B.N. Marbun (1996) noted that SMEs have some significant advantages over large business, as many reasons:

- SMEs have greater flexibility. Small firms can respond quickly to change around them, whereas large firms tend to use many committess to respond.
- Small firms can also fill niches that large firms simply cannot afford to fill.
- Small firms usually is owned and run by the same person. Contrast this to most large corporations, where there is a division between owners and managers. Those individuals who manage the operations of the firms do not typically have substantial ownership in the firms.

Adversely, large business do have advantages where there are truly economies of scale, the ability to do thing cheaper when they are done in large volume. The large firms' system may be efficient, but not able to handle doing small volumes of a particular activity.

On the other hand, SMEs have common disadvantages:

- Rarely had written strategies planning, as a result, SMEs often get lack of orientation on their vision on mission. SMEs usually have inadequate horison of planning, so SMEs tend to follow seasonal trends on running the business rather than make their own trends..

- b). Irrelevant on formal competencies. Most of SMEs entrepreneurs have strongly motivations and spirit, but without appropriate competencies.
- c). Easily to satisfy themselves; the longer SMEs operated, the fastest SMEs deteriorated. SMEs which had been established for a longer time, would turn out to bankruptcy because of inappropriate discipline on management.
- d). Obscure to understood for regulations or policies. As for an example: plagiarism of a well known brand of merk. SMEs are seemed to make the same product as previously famous, without knowing appropriate the patent right.

Why people choose to have their own business? Option to start a new business is often affect by some particular event or condition within an individual 's environment. These triggers tend to encourage the forming of new small business, as they encourage individuals to think creatively. Individuals get comfortable with their lives, and it takes a trigger to force them to think in new ways. Many people do start their business when one of these triggers is present.

Small business owner can be motivated by as many different factors. However, there is some consistency within the variety of motivations. Particularly small business owners have two common motivations, i.e (a). the desire to be their own bosses, and (b). the potential for significant personal and financial reward.

In Indonesia motivations to become entrepreneurs are still minimum because of these many reasons:

- a). People do not like to have an income uncertainty and also risk uncertainty.
- b). Lackness of previous experience and or experiments.

Staley and Morse (1970) inspired that typical business which appropriate in such small business have following pattern:

- a). Small business which produces varied product or varied services to serve varied type of consumers, that large business can not produce because of this type of business needs intensif interaction with their consumers.
- b). Small business that produces hand-craft. This tipe of business uses human skills or

competencies more than machines activities.

- c). Small business which serves a small number of market. This is typed by a small demand on each type of consumers. As a consequences, this business only generates a small number of income, and so large business would not like to contribute in the business.

### 3. Methodology

#### 3.1 Object Research

Objects of this research were several entrepreneurs (small business entrepreneurs) who survive in running their business in Pangandaran tourism areas. They were selected because they can survive running their business for more than ten years. Each entrepreneurs represented one of products/ services available in such tourism areas. There were eight entrepreneurs interviewed representing such following small business: primary meals (foods, drinks, fruits, vegetables), daily-clothes, souvenir-clothes, seafood, sea-crafts. Derivatif sea-products, and simple motels.

The selection process of those samples was conducted on preliminary study by visiting Pangandaran tourism areas, asking some origins people who live and know about tourism areas for many decades.

During interviewing entrepreneurs, data were collected using quistionnaires as a guidance. The quistionnaires including many important point about motivations, problems and success factors of the entrepreneurs. Data collected were tabulated on a matrix named as Matrix of Entrepreneur Growth. So, at the end, eight matrix of entrepreneurs growths had been collected for analysing and developing research conclusions.

As for illustration, methodology of study was simply figured at following Figure 3.

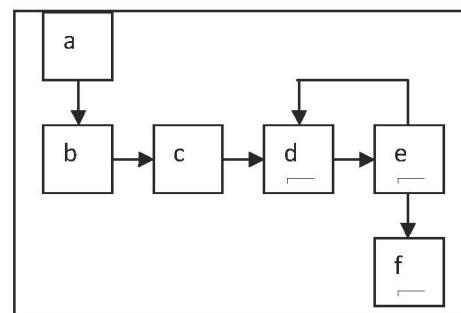

Figure 3. Stage on Methodology Study

- a. Definition aims of study
- b. Preliminary study
- c. Developing questionnaires
- d. Interviewing
- e. Data analysing
- f. Developing conclusion

#### 4. Research Findings and Discussion

Some findings were found by conducting this research:

- a). Motivation: all (8/8) of SMEs entrepreneurs interviewed, began to create their business by trial and error. They came from families with economically not good. The highest formal background educations was senior high school, even one of the entrepreneurs (1/8) illiterated (can only read number, not letters). Option to be entrepreneurs were considered as a better option rather than to be a farmer or a fisherman, eventhough all options have the same thing as its depend on season.
- b). Problems faced: during running their business, they often to change their products, in accordance to adaptability to dynamic surrounding physic environment and alteration of government regulations. They should change their type of product (i.e previously prepare seafood, but next time should change business to prepare clothes), or be consisten with one product but should be able to move to different place or site. For example: the tourism areas was limited, so bus terminal was located in front of tourism market. However in the afternoon, tourists are concentrated in the

beach to swim and many other activities, and in the night, activities of tourists are not in the beach, but in many other places such as hotels or motels, in the centre of tourism areas.

- c). Success factors: in common, entrepreneur who could survive running the business for a long time, has adequate knowledge on entrepreneurship by learning by doing and has good endurance on market fluctuation (on weekdays, their business were not full operated until next weekend or holiday).

#### 5. Conclusion

- a). Motivation: entrepreneurs were strongly motivated by their-selves because of their life background.
- b). Business problems: adaptability to respond dynamic environment in a tourism area.
- c). Success factors: understanding of entrepreneurship by learning by doing, even though their formal background education levels are not enough good.

#### References

- Bamford, C. E., (2010), *Entrepreneurship: A Small Business Approach*, McGraw-Hill International Edition, USA,.
- Das, M, (2001), *Women Entrepreneurs From India: Problems, Motivations and Success Factors*, Jurnal of Small Business and Entrepreneurship.
- Mu'minah, I, and Lubis, H, (2001), *Peluang Usaha Kecil di Kawasan Wisata Pangandaran*, Thesis Magister ITB, unpublished.