

IMPLEMENTATION OF IoT-BASED SMART PARKING USING RFID

Nisa Anggraini ¹⁾, Siti Maryam Dwiyantri ²⁾, Tasya Amalia Putri ³⁾, Yandha Pradita Sari ⁴⁾, Anggi Christian Lusambudi ⁵⁾, Ari Purno Wahyu ⁶⁾

¹⁾²⁾³⁾⁴⁾⁵⁾⁶⁾ Informatics Engineering, Widyatama University

Jl. Cikutra No.204A, Sukapada, Kec. Cibeunying Kidul, Kota Bandung, Jawa Barat 40125

Corresponding author: nisa.anggraini@widyatama.ac.id

Abstract

The parking area is urgently needed in public places such as malls and so on. As time goes by, the development of the productivity of a car in Indonesia evolving so rapidly so that an empty parking lot will also be more and more hard to find. The drivers will be hard to find a parking space so that it will keep spinning to looking for the empty parking spaces, it certainly will make the drivers confusion about which makes the drivers does not park their car. Even lately, the case of car theft in parking lots has increased greatly due to security systems and data that have not been properly managed. The parking area usually using conventional tickets that are easily lost and fell from a pocket that can be stolen by thieves and thieves will take the stolen car from the parking lot and escape using that ticket. This problem can be solved by smart parking system. Smart parking system is a system that can facilitate drivers looking for parking and parking transactions. In this research the researcher will using ethernet shield for sending the data from system to web or vice versa. The aim of his research is to build a smart parking system from transaction and monitoring of parking slots that can be seen on the website. The system consists of a microcontroller, using MFRC522 for transactions, using ultrasonic to detect parking slots, ethernet shield to send the data to database for display parking slot data on website and from database sent to LCD for display user data.

Keywords: Smart Parking System, monitoring, MFRC522, ultrasonic, LCD, user, ethernet shield, website.

Introduction

In the current era, there are many tools that run automatically and that can be connected remotely, namely IoT. Internet of Things (IoT) is a network that connects various objects that have identifiers and Internet Protocol (IP) addresses, so they can communicate with each other and exchange information about themselves and the environment they sense. Objects in IoT can use or produce services and work together to achieve a common goal. With this capability, IoT has shifted the definition of the internet as computing anywhere, anytime, to anything, anyone and any service. One issue that is still a weakness in IoT implementation is the issue of security and privacy. Attacks on IoT security can include attacks on Radio Frequency Identification (RFID) labels, communication networks as well as on data privacy. To prevent and overcome it, security mechanisms and protocols are needed.

One of the existing problems is the Parking System. Parking areas are needed in public places such as malls and so on. Over time, the productivity of cars in Indonesia is growing so rapidly that even empty parking spaces will be increasingly difficult to find. Drivers will find it difficult to find an empty parking space so they will continue to spin to find an empty parking space, of course it will make motorists confused which can make drivers not park their vehicles. Even recently, cases of car theft in parking lots have increased rapidly due to the lack of security and verification of parking data. Usually parking uses a conventional ticket that can easily be lost from your pocket or fall and can be picked up by someone else, which can be used to take a car that is not yours out of the parking lot (Maciej Kozłowski , Andrzej Czerepicki , Piotr Jaskowski , Kamil Aniszewski, 2021)

There are several studies on RFID and Booking Systems utilizing IoT. Research is developing a parking system that is more cost effective and user friendly. The tool that is made is that the parking lot is stored with ultrasonic sensors, if there is a parked car, the data will be input to the Arduino and then to the wireless which is sent by the web and output LED. So if the parking lot is empty the LED light is green, if it is filled the LED light is red (Shaik Saidu Masthan ; Dr.Christeena Joseph, 2020)

Literature Study

Research makes a project that offers a web-based parking reservation system, where users can view various parking areas and can choose available parking spaces. The research describes the parking system using

RFID to read incoming car rates. So there will be no mistakes in paying the parking fee. So every car must have an RFID card to be scanned when entering and will start calculating the rate, then when leaving the driver must scan the card again to display the estimated rate (Amir Shimi, Mohammad Reza Ebrahimi Dishabi, Mohammad Abdollahi Azgomi, 2020)

After analyzing, there are several shortcomings in the studies described in the lecture, namely the research is still lacking in terms of security, cases of theft can't be detected by the system. Research, undetected which parking spaces have been filled and haven't been completed, there is a possibility of fighting over parking. As for the RFID system in the study, it has not been able to detect the data of the original owner of the car, which may lead to theft (Vladimir Sobeslav ; Josef Horalek, 2020)

From the statement above, for further development that improves existing research, including in terms of security, a process enable replacing widely registered RFID cards, not only for the tapping process as in research and each RFID card entered in the card owner's personal data. RFID and its balance aren't only used to process balance transactions, as in research. In addition, in terms of monitoring quality, it is proposed that the system can detect empty parking slots by looking at the website using ultrasonic sensors to improve research (Jiří Hanzla, 2021)

Internet of Things (IoT) is a network that connects various objects that have identifiers and IP addresses, so they can communicate with each other and exchange information about themselves and the environment they sense. Objects in IoT can use or produce services and work together to achieve a common goal. With this capability, IoT has shifted the definition of the internet as computing anywhere, anytime, to anything, anyone and any service. One issue that is still a weakness in IoT implementation is the issue of security and privacy. Attacks on IoT security can include attacks on RFID labels, communication networks or on data privacy. To prevent and overcome it, security mechanisms and protocols are needed. For the functioning of the RFID system, a reader or scanning device is needed that can read the tag correctly and communicate the results to the microprocessor/microcontroller (Ghulam Ali 1, Tariq Ali 2,*, Muhammad Irfan 3, Umar Draz 4,*, Muhammad Sohail , Adam Glowacz , Maciej Sulowicz , Ryszard Mielnik , Zaid Bin Faheem , Claudia Martis, 2020)

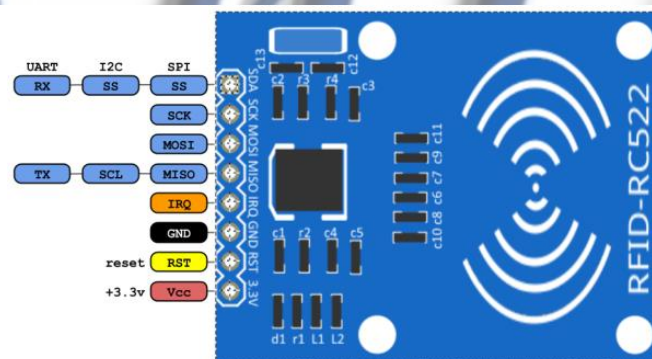

Fig. 1 RFID Reader

Communication between TAG and Reader can be via serial USART, i2c and SPI. In this article, serial SPI is used to read and write data to TAG memory. Reads and writes are done by Arduino. Android is a subset of software for mobile devices that includes an operating system, middleware and core applications released by Google. As a complement is the Android SDK (Software Development Kit) which provides the tools and APIs needed to develop applications on the Android platform using the Java programming language. Android was developed jointly by Google, Intel, Motorola, Qualcomm, T-Mobile, NVIDIA and 47 other companies that are members of the OHA (Open Handset Alliance) with the aim of creating an open standard for mobile devices. In addition to code numbering into each version, Android is also given a name in the form of food names according to the letters of the alphabet. In the first version known as Cupcake with Android version number 1.5. The second version is named Donut with version number 1.6 released September 15, 2008. The third version as clair consists of 2 versions, namely Android 2.0 and 2.1 released one month after Donut was launched. The fourth version is Froyo released in May 2010 with version number Android 2.2. Next is Gingerbread which was released around December 2010 with version number 2.3. Honeycomb with Android 3.0 version number. Ice Cream Sandwich version with version number Android 4.0 as well as Jelly Bean version (Samar Alkhouraji, 2021)

Research Method

Conventional parking system Still requires HR at entry point / entry access, postal officers enter to enter the vehicle registration number. Customers / visitors take tickets at the ticket dispenser. Equipped with a key number for ticket verification at the exit post. If the verification process is correct, the new automatic barrier gate can open. The process of opening and closing the automatic barrier gate is carried out with the following system.

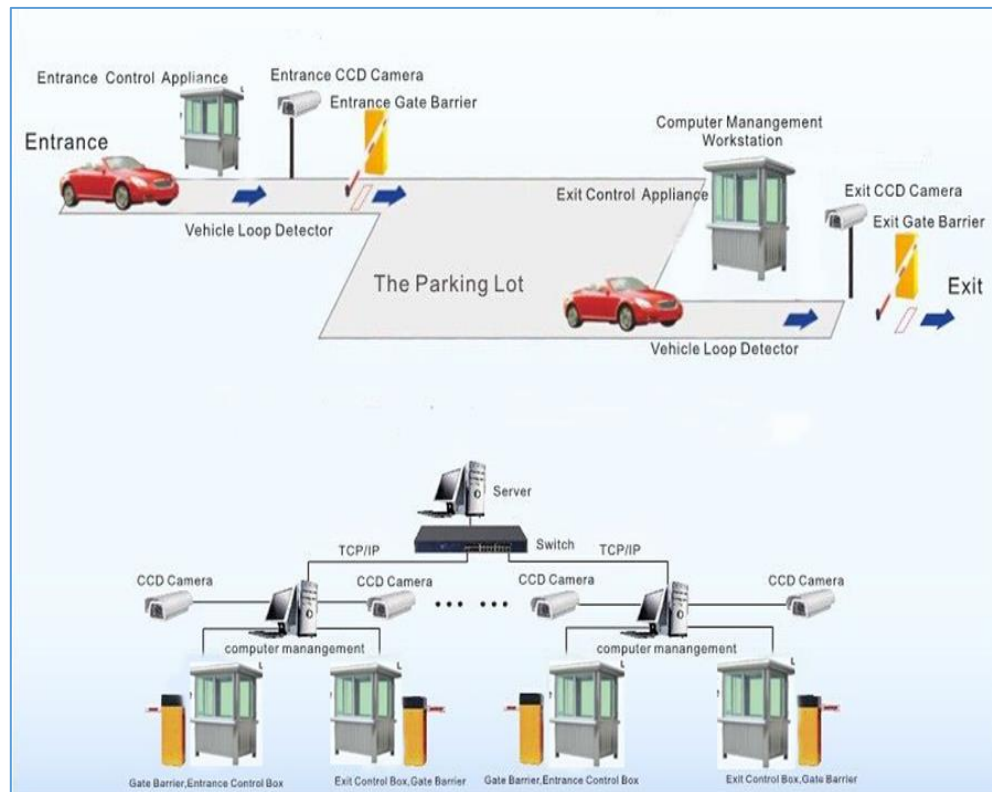

Fig.2 Conventional Parking System [Source: Parking Tis]

For technological feasibility, this device can be used because it uses RFID which can facilitate transactions and uses the web for parking monitoring which can be used by everyone. This device uses the Arduino Mega 2560 Rev 3 microcontroller as the central controller. This technology is also easy to use. The monitoring system can be used anywhere because it can be viewed via the web and for the transaction system, it is only by scanning a registered RFID Card that it is easier to use and faster.

Implementation System

In this system, the user can find out the available parking slots and the user can easily make transactions quickly. Users can see available parking slots through ultrasonic sensors installed in each parking slot, ultrasonic will read in each parking slot whether there is a car or not. If the parking slot is empty, ultrasonic will send data to Arduino and then send data to the database via ethernet shield and then display information to the web with the output "empty", if the parking slot is filled, the data will also be sent to the web as well but if the parking slot is filled the output is "yes".

For user transactions, the user comes to the parking lot and then scans his RFID card to the RC-522, then the data will be sent and matched with the data in the database. If the data is correct, the consumer data will appear on the LCD and the parking bar will open, while if the data is incorrect, the parking bar will not open and the LED will be red. Then for parking exit transactions, the user will also scan his RFID to the RC-522 which is available at the parking exit barrier. The data is scanned and then matched again to the database. If the data is correct, the consumer's balance will be reduced and updated and then displayed on the LCD and the exit bar will open, while if the data is incorrect, the LED will be red and the exit bar will not open.

Data Flow Diagram (DFD) serves as a modeling tool that allows system professionals to describe the system as a network of functional processes that are connected to each other by data flows, either manually or

computerized. DFD (Data Flow Diagram) has a function as a system design tool that is oriented to data flow using the concept of decomposition, which can be used to describe the analysis and design of systems that are easily communicated by system professionals to users and program makers. The following is a Level 1 Data Flow Diagram for an IoT-based parking system using RFID.

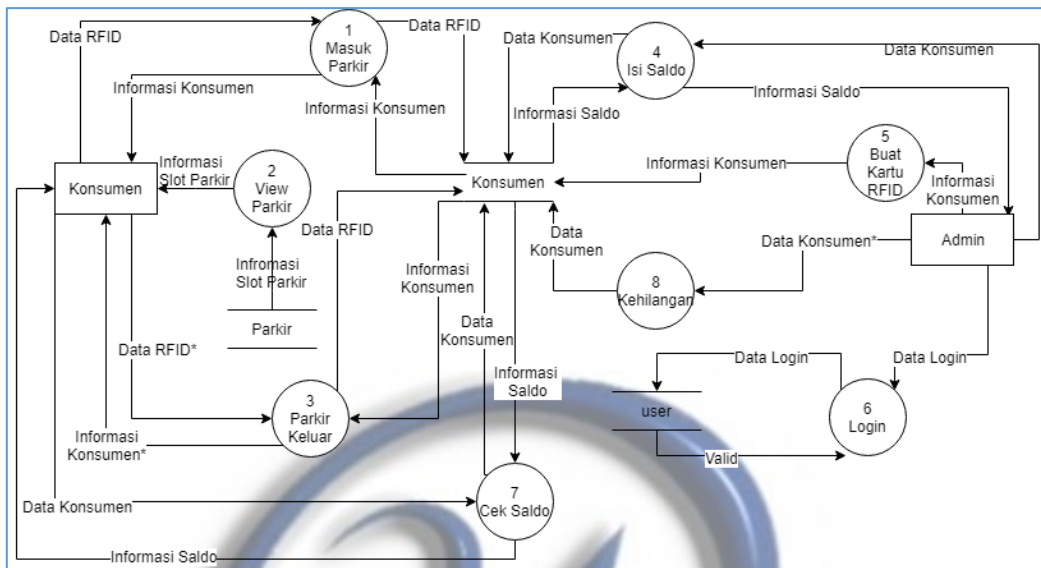

Fig.3 SiPaR and DFD

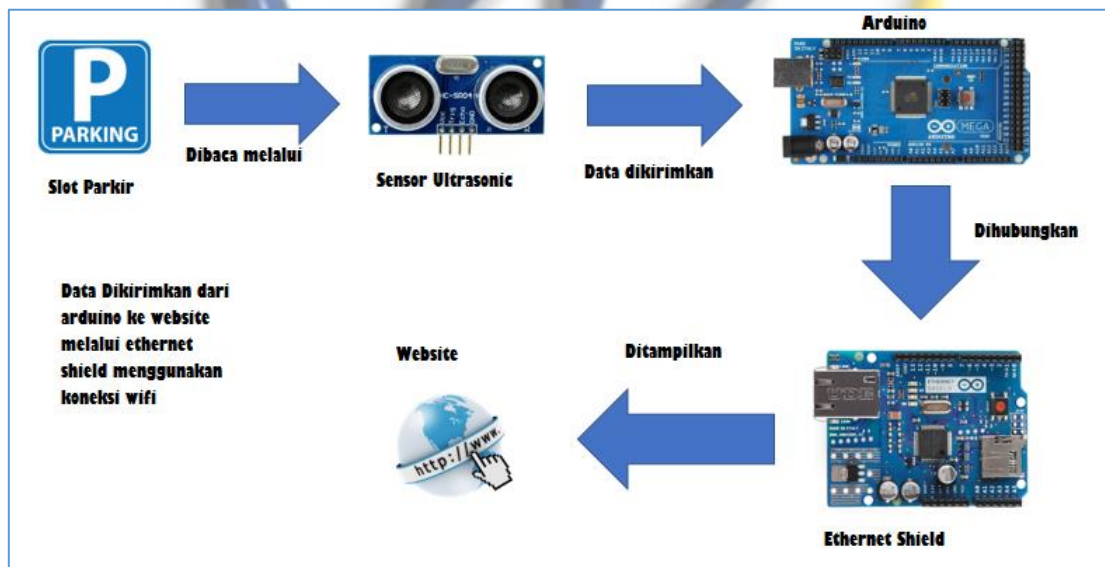
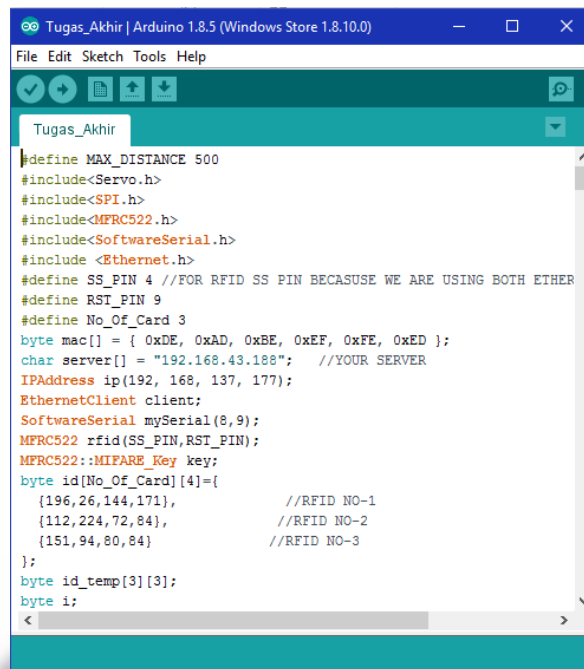

Fig.4 Schematic of the available parking slot monitoring system

Figure 4 shows the available parking slot monitoring system scheme, starting from the parking slot detected by the ultrasonic sensor, then the data is sent to Arduino Mega, then the data is displayed to the web via the Ethernet shield first. This LCD series with Arduino Mega and Ethernet Shield is used to display consumer data (name and balance) after scanning the RFID card on the MFRC522. This circuit retrieves data from the database via the Ethernet Shield which has been connected to the Arduino Mega. In Figure 4, you can see the LCD design scheme with Arduino Mega and Ethernet Shield. In designing an IoT-based parking system using RFID, software is needed to send the program into the microcontroller. The software is Arduino SDK. Arduino SDK (Software Development Kit) is a software used to do programming for Arduino devices. Fig.5 shows an image of the Arduino SDK.



```

Tugas_Akhir | Arduino 1.8.5 (Windows Store 1.8.10.0)
File Edit Sketch Tools Help
Tugas_Akhir
#define MAX_DISTANCE 500
#include<Servo.h>
#include<SPI.h>
#include<MFRC522.h>
#include<SoftwareSerial.h>
#include <Ethernet.h>
#define SS_PIN 4 //FOR RFID SS PIN BECAUSE WE ARE USING BOTH ETHER
#define RST_PIN 9
#define No_Of_Card 3
byte mac[] = { 0xDE, 0xAD, 0xBE, 0xEF, 0xFE, 0xED };
char server[] = "192.168.43.188"; //YOUR SERVER
IPAddress ip(192, 168, 137, 177);
EthernetClient client;
SoftwareSerial mySerial(8,9);
MFRC522 rfid(SS_PIN,RST_PIN);
MFRC522::MIFARE_Key key;
byte id[No_Of_Card][4]={
  {196,26,144,171},           //RFID NO-1
  {112,224,72,84},           //RFID NO-2
  {151,94,80,84}             //RFID NO-3
};
byte id_temp[3][3];
byte i;

```

Fig.5 Arduino SDK

Referring to the previous chapter, namely the analysis and design of systems on IoT-based parking system devices using RFID, for parking in and out systems using RFID to be scanned when entering and exiting parking, using green and red LEDs and buzzers for true or false warnings when scanning RFID, and LCD to view or display user data from the scanned RFID card along with displaying the balance. (Ria Mutiara Sari, Eka Sabna, Refni Wahyuni, Yuda Irawan, 2021). The LCD module is installed on the Arduino so that it can display user data from the scanned RFID and display the balance when entering the parking lot and exiting the parking lot as shown in Fig.6 below..



Fig.6 Implementation of LCD Module

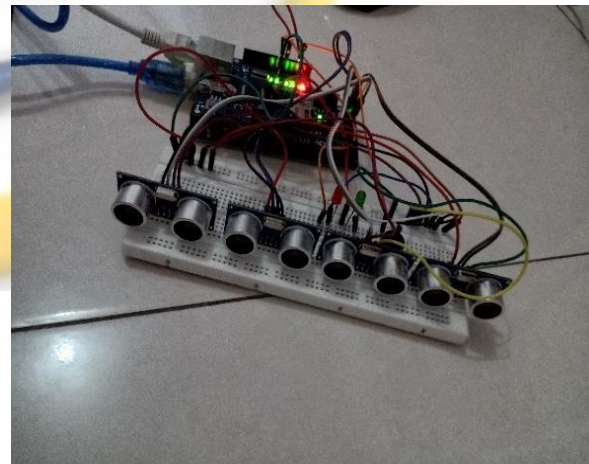

Fig.5 Ultrasonic Implementation

Figure 6 is a series of installation of the LCD Module on Arduino. In order to be used as a monitoring system, the LCD module is installed according to the pins. The yellow cable on the LCD module is connected to the GND pin on the Arduino mega, the orange cable on the LCD module is connected to 5v on the Arduino mega, the red cable on the LCD module is connected to SDA on the Arduino mega pin, the brown cable on the LCD module is connected to SCL on Arduino mega. As explained in the analysis and system design chapter, to carry out monitoring using an ultrasonic sensor that functions as a distance detector whether the parking slot is empty or not. The ultrasonic sensor is set at a distance of less than 6 cm to detect whether a parking slot is available or not.

The ultrasonic sensor used is 4 sensors which are connected to Arduino as shown in Figure 5 is a series of 4 ultrasonic sensors installation on Arduino mega. In order to be used as a monitoring system, 4 ultrasonic sensors are connected to the Arduino Mega according to the pins. The black wire on the ultrasonic sensor 1 is connected to 5V on the Arduino mega, the white wire on the ultrasonic sensor 1 is connected to pin 26 on the Arduino mega, the gray wire on the ultrasonic sensor 1 is connected to pin 27 on the Arduino mega, the purple wire on the ultrasonic sensor 1 is connected to GND on the Arduino mega. The red wire on the ultrasonic sensor 2 is connected to 5V on the Arduino mega, the purple wire on the ultrasonic sensor 2 is connected to pin 28 on the Arduino mega, the gray wire on the ultrasonic sensor 2 is connected to pin 29 on the Arduino mega, the black wire on the ultrasonic sensor 2 is connected to GND on the Arduino mega. The purple wire on the ultrasonic sensor 3 is connected to 5V on the Arduino mega, the gray wire on the ultrasonic sensor 3 is connected to pin 30 on the Arduino mega, the white wire on the ultrasonic sensor 3 is connected to pin 31 on the Arduino mega, the yellow wire on the ultrasonic sensor 3 is connected to GND on the Arduino mega. The red wire on the ultrasonic sensor 4 is connected to 5V on the Arduino mega, the gray wire on the ultrasonic sensor 4 is connected to pin 32 on the Arduino mega, the black wire on the ultrasonic sensor 4 is connected to pin 33 on the Arduino mega, the green wire on the ultrasonic sensor 4 is connected to GND on the Arduino mega.

Conclusion

The RFID scanning system at parking entry and exiting the parking lot has been able to work well, namely being able to scan which RFID cards have been registered and not by checking first by sending RFID data to the database, and can be connected to the servo for the crossbar and LCD to display user data from database as well as warnings from the LED and buzzer.

The parking slot detection system has been able to work well, namely the ultrasonic sensor can detect the presence of a parked car or not, then sends the data to the database to be displayed on the web via Ethernet Shield. Then on the web you can see which parking slots are empty and which are filled

After seeing the simulation results and conclusions from "Implementation of IoT-Based Smart Parking Using RFID", it can be developed into a better system. The things that can be developed from the system are as follows:

- Development of parking slot monitoring from the web into a smartphone application.
- Add or combine smart parking with security systems such as cameras or cctv.
- Adjusting the scaling for real conditions such as car detection distance, in the simulation it is given 6cm, for real conditions it is given a distance of about 50 cm.
- Using stronger power for real conditions, due to more sensors so that the system runs smoothly.
- For parking bars, you can use a metal detector so that the parking bars open and close according to the presence of vehicles entering or leaving.

Reference

- Amir Shimi, Mohammad Reza Ebrahimi Dishabi, Mohammad Abdollahi Azgomi,. (2020). *An Intelligent Parking Management System using RFID Technology based on User Preferences*. , Miyaneh, Iran: Department of Computer Engineering Miyaneh Branch, Islamic Azad University.
- Ghulam Ali 1, Tariq Ali 2,*, Muhammad Irfan 3, Umar Draz 4,*, Muhammad Sohail , Adam Glowacz , Maciej Sulowicz , Ryszard Mielnik , Zaid Bin Faheem , Claudia Martis. (2020). IoT Based Smart Parking System Using Deep Long Short Memory Network . *MDPI*.
- Jiří Hanzla. (2021). Design of Incentive Parking Lots in the Region – Conception, Technology and Pricing Policy. *Transportation Research Procedia 53 (2021) 244–251 ScienceDirect*.
- Maciej Kozłowski , Andrzej Czerepicki , Piotr Jaskowski , Kamil Aniszewski. (2021). Analysis of the System of Controlling Paid Parking Zones. *MDPI*.
- Ria Mutiara Sari, Eka Sabna, Refni Wahyuni, Yuda Irawan. (2021). Implementation of Open and Close a Housing Gate Portal Using RFID Card. *Journal of Robotics and Control (JRC)*, 2(5).
- Samar Alkhurajji. (2021). Design and Implementation of an Android Smart Parking Mobile Application. *TEM Journal*.
- Shaik Saidu Masthan ; Dr.Christeena Joseph. (2020). Design of Smart Bus Ticketing System using IoT and RFID. *International Journal of Control and Automation*, 1267- 1272.
- Vladimir Sobeslav ; Josef Horalek. (2020). A Smart Parking System Based on Mini PC Platform and Mobile. *Hindawi* .

